



MEKA

VERTICAL SHAFT IMPACT CRUSHERS

EXCEPTIONAL MINERALS
BENEFICIATION CAPABILITIES

MEKA CRUSHING SCREENING AND
CONCRETE BATCHING TECHNOLOGIES
www.mekaglobal.com



VERTICAL SHAFT IMPACT CRUSHERS (VSI)

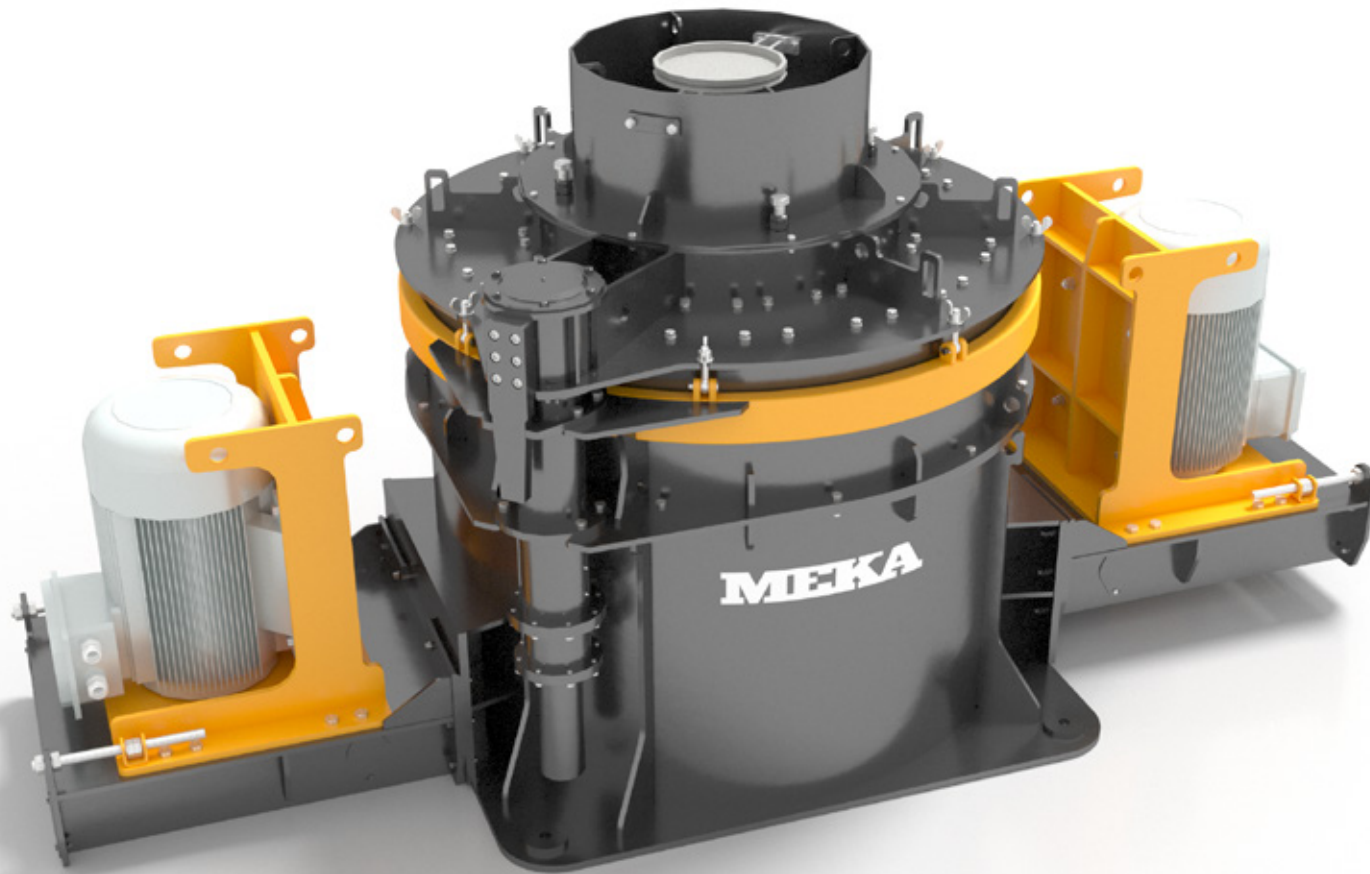

Vertical Shaft Impact (VSI) crushers are designed to be used in secondary, tertiary or quaternary stage crushing. The crushers are suitable for a wide range of applications including the production of high quality manufactured sand, well formed aggregates and industrial minerals. Crushers can also be used for shaping or removal of soft stone from aggregate.

Advanced alternatives with open table designs, multi-port rotor and larger bearings than many other VSI crushers are the main reasons for our crushers to provide high value solutions and deliver high performance. We provide static, wheel mounted VSI plants and components.

Operational reliability, cost effectiveness and reliable service are our "MUSTS". We have over 30 years of experience in concrete and crushing industries. We offer you latest technology, flexible and customised designs.

Applications

- . Manufactured sand
- . Re-crush of slow selling stocks
- . Cubical products
- . Fractured gravel
- . Material beneficiation
- . Crushing of cement clinker before mills
- . Glass recycling

DESIGN FEATURES

- Fully welded construction
- Large receiving hopper
- Heavy duty main pedestal
- Drop in style, oil lubricated bearing assembly having ample dimensioned spherical roller bearings
- Hydraulic lid lifter mechanism
- Externally adjustable feed tube system with a convenient inspection door mounted on the lid, provides safe and easy inspection
- Lid and main frame protection with special alloy wear resistant liners
- Tungsten carbide component on rotor
- Preparations for water spray piping system mounting to avoid material build up underneath rotor
- V Belt drive guard prevents dust intrusion to the V-Belt drive
- Air transfer system enables internal air circulation and reduces dust emission
- Bearing assembly mounted into a rigid base frame support provides maximum strength ideal for large feed or high speed applications
- Flexible crushing chamber options
- Modular oil system includes 160 liters(42 gallons) oil tank, gear pump, relief valves for low pressure oil circulation and high pressure lid lifter circuits, low flow rate shut down switch, oil heater, oil level gauge, oil temperature and lube oil pressure gauges
- Safety features includes; open lid safety lock, low oil flow rate and high oil temperature shut off switches.
- Excessive vibration alarm system that includes a maintenance alarm to alert you to potential problems. If excess vibration occurs, the vibration switch will shut down the crusher to protect it from possible damage.
- Dual drive design reduces the radial and thrust loading on the electric motors, resulting in an extra-long service life for the motors.



MEKA

VERTICAL SHAFT IMPACT CRUSHERS (VSI)

KEY BENEFITS

- High crushing reduction percentage
- Simple maintenance
- Low capital investment
- Low energy and wearing parts costs per ton of product
- High cubicity (shaping)
- Elimination of soft stone
- Gradation consistency
- High production capacity



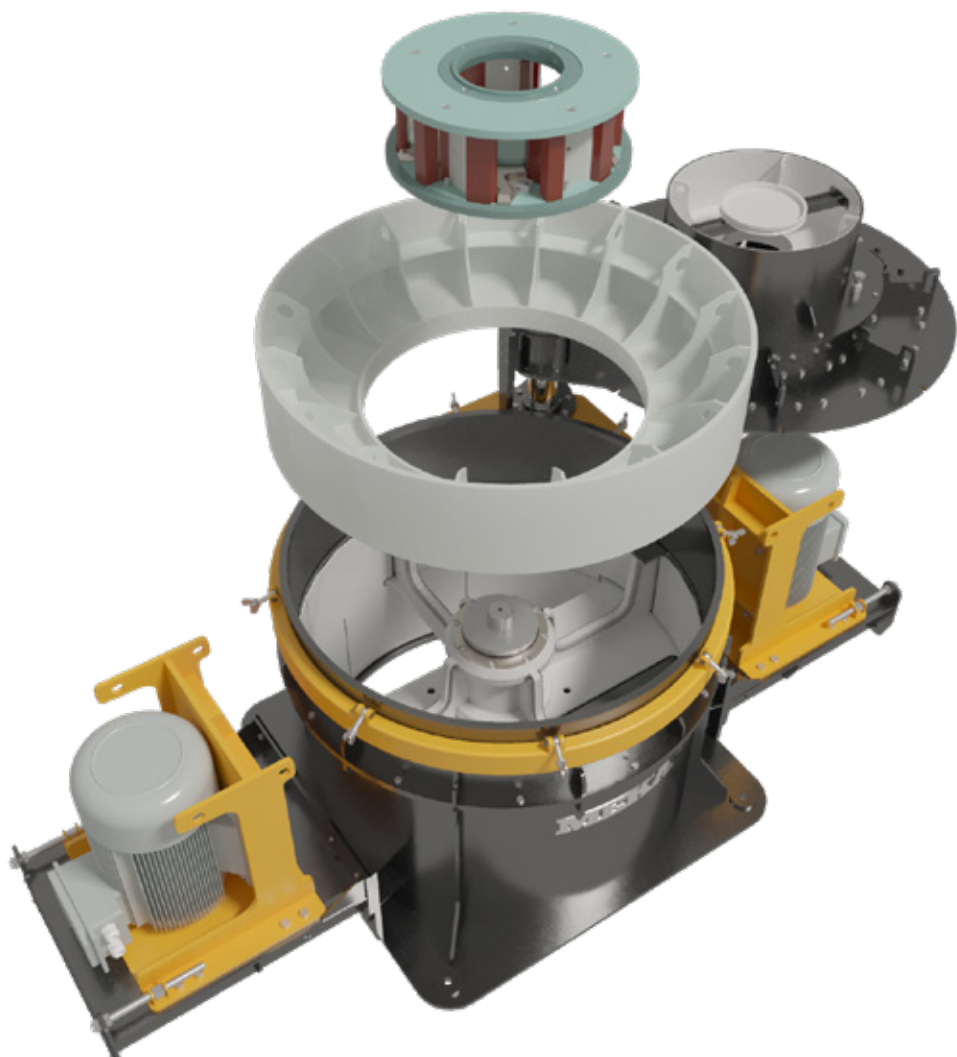

APPLICATION OF CLOSED ROTOR AND ROCK SHELF ROCK ON ROCK (ROR)

- ROR configurations are recommended when crushing the most abrasive materials, in tertiary and quaternary applications where additional fines production is desired.
- Autogenous crushing occurs inside crusher chamber between material thrown from rotor and material resting on rock shelf or material springing back from rock shelf.
- Production of cubical high quality aggregates and sand from highly abrasive input materials, such as gravel, granite, quartzite etc.
- Crushing of highly abrasives materials, such as aluminum oxide, ferrosilicon, abrasives, glass etc.
- Selective crushing of slags from steel mills, waste incineration plants etc.

ROR Application For Producing Cubical Shaped Aggregates

Feed Material: Basalt, Gravel, Limestone, Dolomite

Feed Size: 5-25 mm (4M-1")

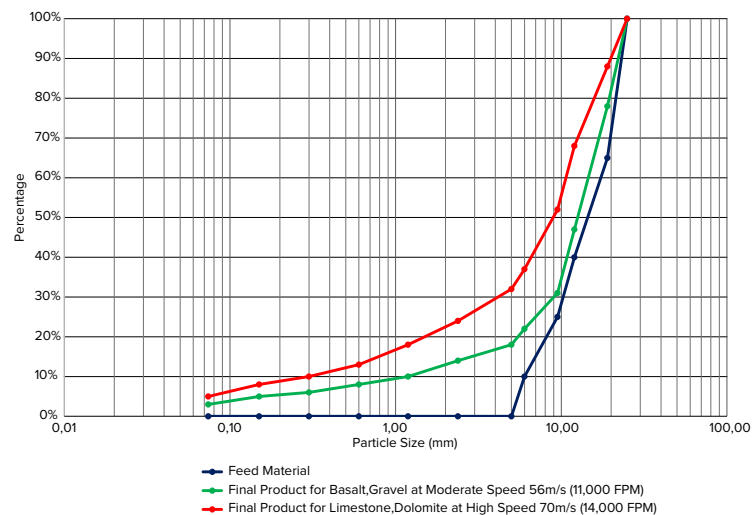

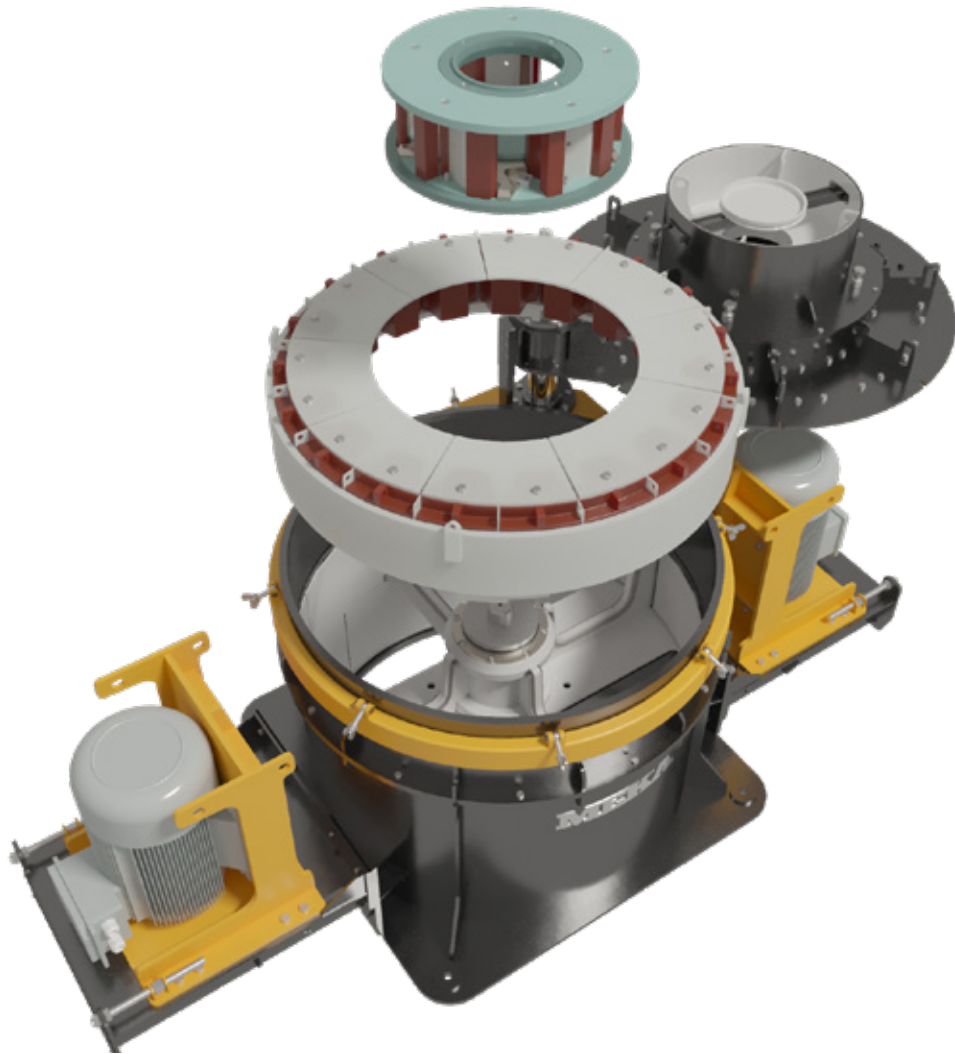

APPLICATION OF CLOSED ROTOR AND ANVIL RING ROCK ON STEEL (ROS)

- Impact crushing on anvils and also autogenous crushing between material springing back from anvils and material thrown from rotor occurs at the same time.
- This type of crushing is recommended for low and medium abrasive materials such as gravel, limestone, dolomite, diabase, bricks, cement clinker etc.
- Production of cubical and high quality sand can be achieved.
- Additional fine production can be obtained with higher rotor speeds.
- Selective crushing of conglomerates, moderately abrasive slags, industrial minerals, mining overburden etc.
- Recycling of asphalt and unreinforced concrete waste.

ROS Application

Feed Material: Basalt, Gravel, Limestone, Dolomite

Feed Size: 5-25 mm (4M-1")

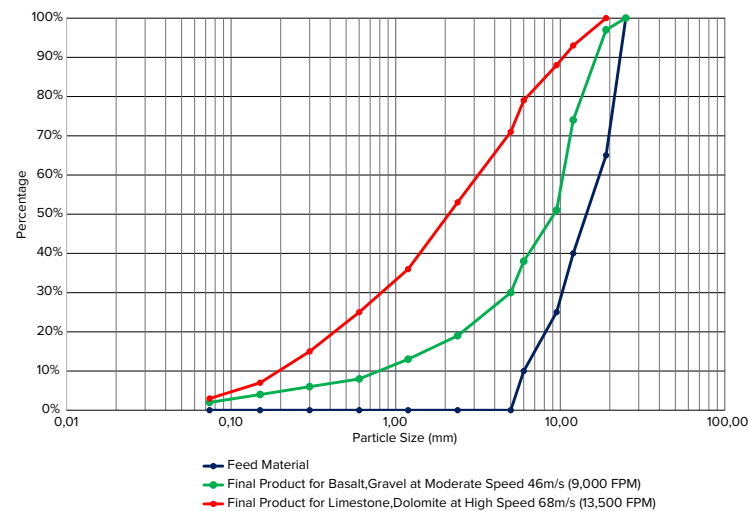

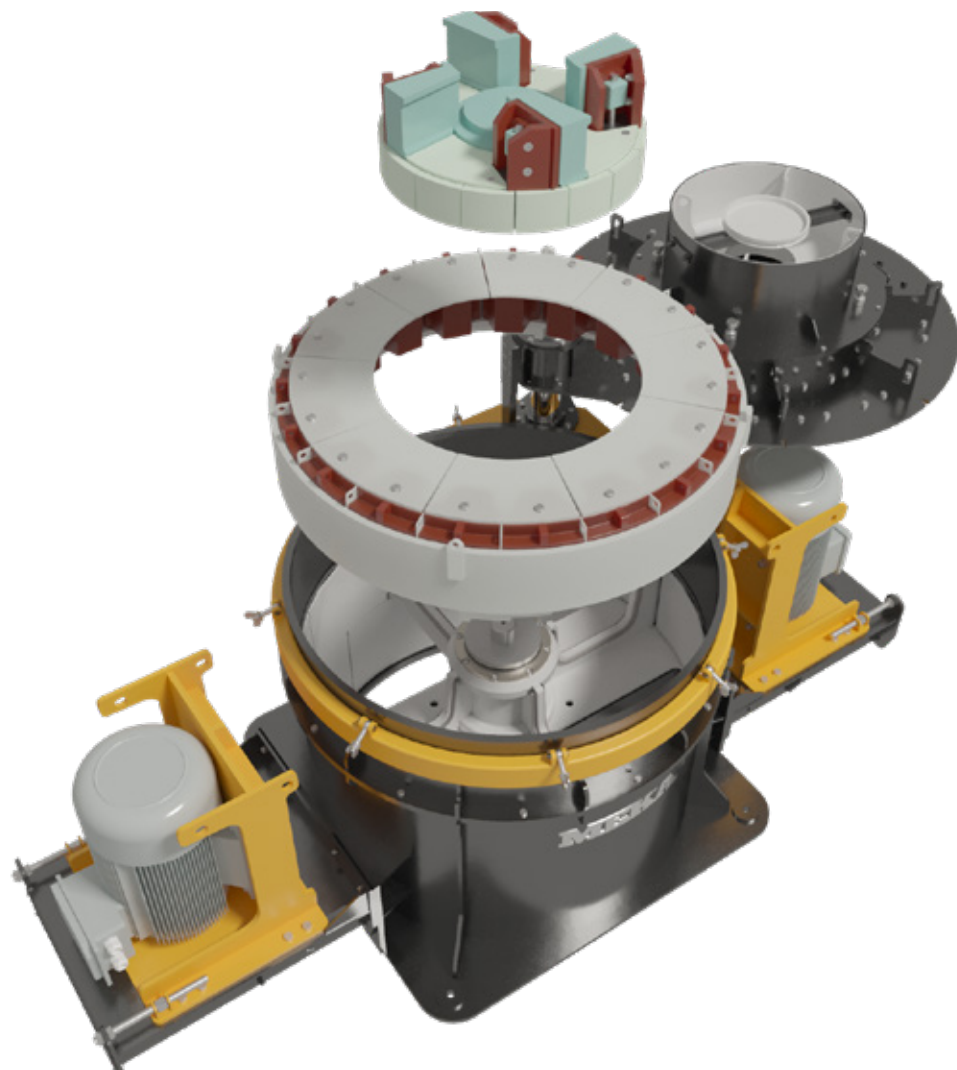

APPLICATION OF OPEN TABLE ROTOR AND ANVIL RING STEEL ON STEEL (SOS)

- Impact crushing occurs on anvil.
- This type of crushing is recommended for non-abrasive or low abrasive materials, such as limestone, in secondary and tertiary crushing applications with larger feed sizes.
- Selective crushing of moderately abrasive slags, industrial minerals, mining overburden etc.
- High capacity production of cubical and high quality sand can be obtained.

SOS Application

Feed Material: Limestone, Dolomite

Feed Size: 12-75 mm (1/2"-3")

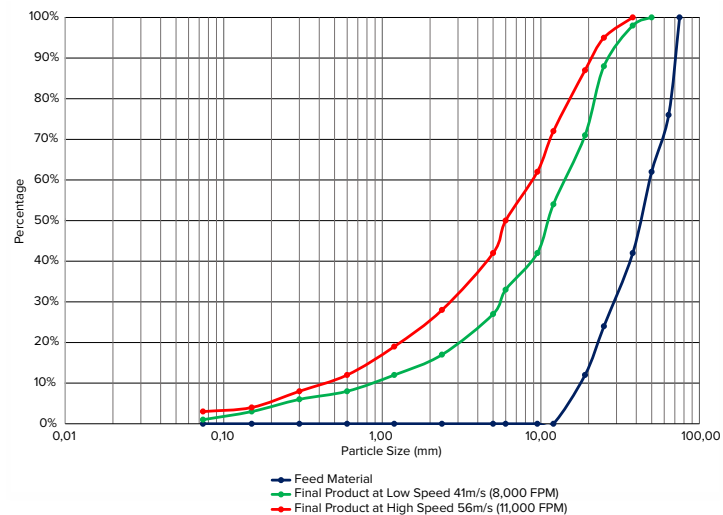

CRUSHING CHAMBER CONFIGURATIONS

ROCK ON ROCK (ROR)

- Enclosed rotor and rock shelf
- Feed sizes up to 50mm (2")
- For all rock types and the most abrasive materials
- Produces the best shaped and most consistent material with the lowest wear cost



ROCK ON ANVIL

(Rock on Steel-ROS and Steel on Steel-SOS)

- Enclosed rotor and anvil
- Feed sizes up to 50mm (2")
- High reduction in medium abrasive materials
- Combine the grinding action of the rotor with the high efficiency reduction of anvils

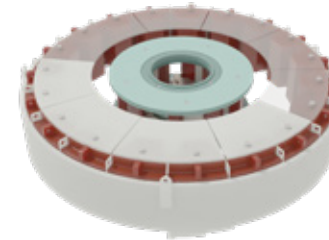

SHOE AND ANVIL

- Open shoe table and anvil
- Large feed mild to medium abrasive materials
- Offers high tonnage of chip production, high reduction ratios and feed size flexibility
- Feed sizes up to 75mm (3")



ROTOR DESIGNS

3/5 PORT ROTOR

- Designed with the fewest parts possible
- Parts interchange between top and bottom
- No hard facing required

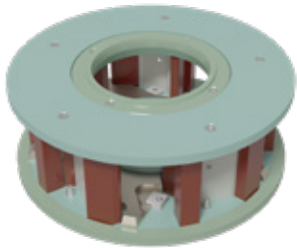

OPEN SHOE TABLE

- 3 and 4 shoes available
- Designed for easy maintenance

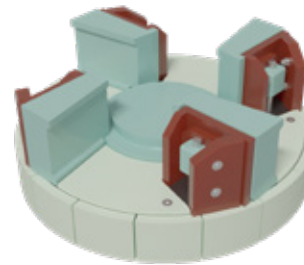



VERTICAL SHAFT IMPACT CRUSHERS (VSI)

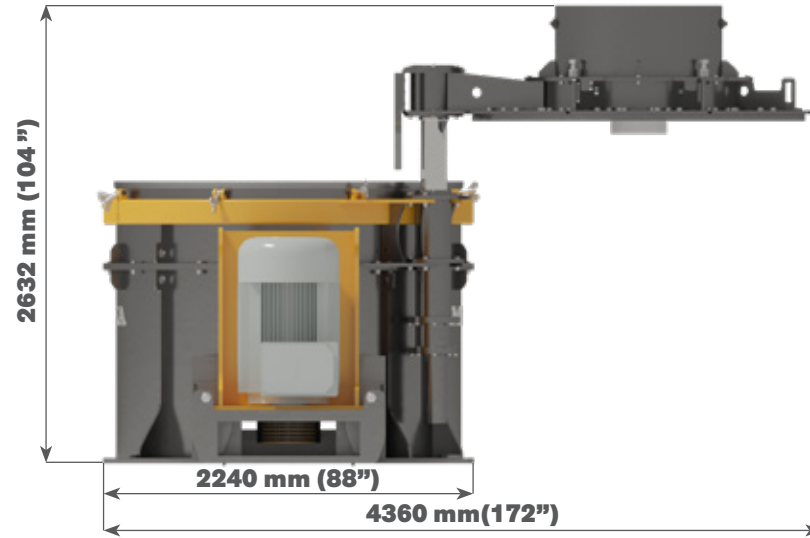
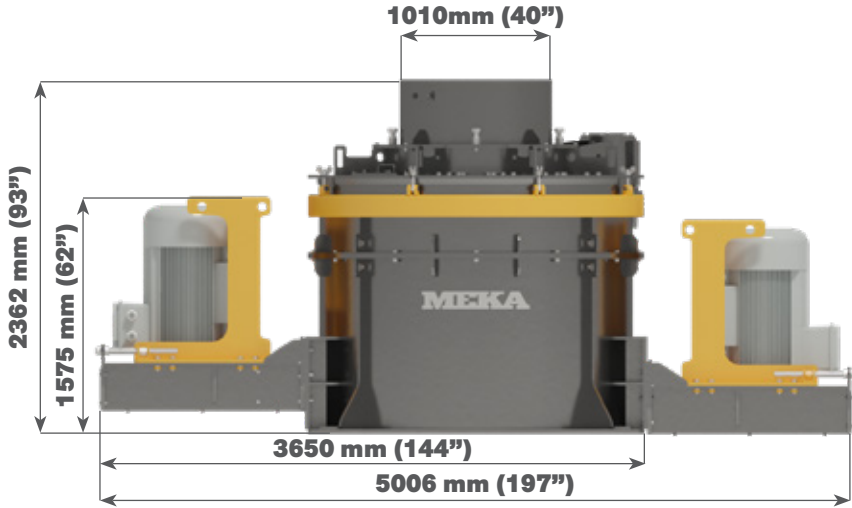

TYPE	MAX FEED SIZE		POWER		CRUSHER WEIGHT		SPEED	MAX CAPACITY*	
	(mm)	(inch)	(kW)	(HP)	(kg)	(lbs)	(rpm)	(mtph)	(stph)
MV 90 ROR <i>Single Drive</i>	50	(2")	200	275	10900	23980	800 - 1700	200	220
			250	335	11200	24640	800 - 1700	250	275
MV 90 ROR <i>Dual Drive</i>	50	(2")	2 X 110	2 X 150	12200	26840	800 - 1700	200	220
			2 X 132	2 X 180	12400	27280	800 - 1700	250	275
			2 X 160	2 X 220	12600	27720	800 - 1700	300	330
MV 90 ROS <i>Single Drive</i>	50	(2")	200	275	13200	29040	800 - 1600	200	220
			250	335	13500	29700	800 - 1600	250	275
MV 90 ROS <i>Dual Drive</i>	50	(2")	2 X 110	2 X 150	14300	31460	800 - 1600	200	220
			2 X 132	2 X 180	14500	31900	800 - 1600	250	275
			2 X 160	2 X 220	14700	32340	800 - 1600	300	330
MV 90 SOS <i>Single Drive</i>	75	(3")	200	275	13600	29920	800 - 1400	200	220
			250	335	13900	30580	800 - 1400	250	275
MV 90 SOS <i>Dual Drive</i>	75	(3")	2 X 200	2 X 275	15600	34320	800 - 1400	400	440

* Crusher performance may vary depending on the feed gradation, feed moisture content, crushability of the material, crusher rpm, installed power and the crushing circuit design. Please consult MEKA for specific applications.

MEKA

VERTICAL SHAFT IMPACT CRUSHERS (VSI)



MEKA IS A PROFESSIONAL SOLUTION

Meka has developed and manufactured crushing-screening machines, washing equipment, stationary and mobile crushing and screening plants, recycling plants for concrete and asphalt, and concrete batching plants for a great number of customers. Today, there are more than 2,000 Meka plants in over 65 countries on four continents contributing to the construction of a better world. Meka is preferred by global leaders such as Holcim, Lafarge, Cemex, and Heidelberg, and our brand is acknowledged as “the choice of professionals” worldwide.





MEKA

CRUSHING
SCREENING AND
CONCRETE BATCHING
TECHNOLOGIES

HEAD OFFICE

Camlica Mah. Anadolu Bulvari
147. Sokak Atlas İş Merkezi
No:5/9 Gimat ANKARA - TURKEY
+90 312 397 91 33-34-35
Fax: +90 312 397 10 34
sales@mekaglobal.com

www.mekaglobal.com